

### ► Features

- 19" Rack mountable design (2 HE)
- Mounts over two single or one double rackspace
- Hooks accessories such as headphones, patch cables, ...
- Soft covered arm for grip and protection
- 103 mm arm length
- Swivel construction



### ► Description

The RHB10 is a 19" mountable bracket with a height of 2 units which can be mounted over two single rackspace or one double rackspace device.

It allows hooking of accessories such as headphones, patch cables and many others to your 19" flightcase, installation or studio rack. The arm with a length of 103 mm is covered with a soft PVC jacket, offering grip and protection to the hooked equipment. The swivel construction allows easy transportation without disassembly.

### ► Technical Drawing

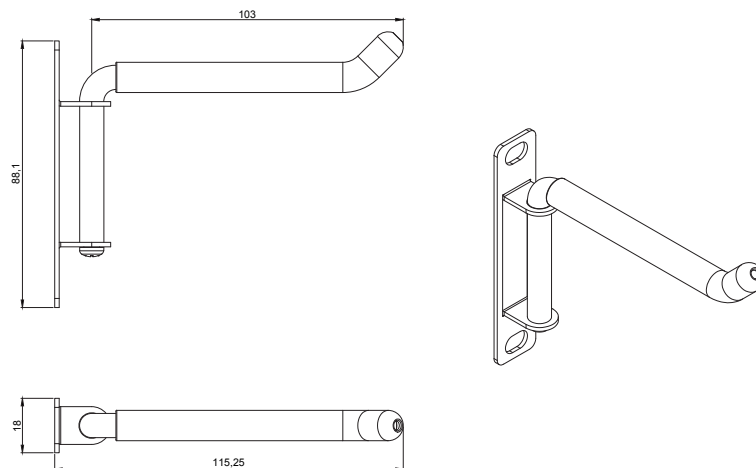

### ► Specifications

PROPERTY	VALUE
Unit height	2 HE
Arm length	103 mm
Arm diameter	Ø 8 mm steel with Ø 11.2 mm soft PVC covering
Material	Steel
Finishing	Black (RAL9004) powder coating
Dimensions	18 x 88.1 x 115.25 mm
Weight	0.082 Kg