

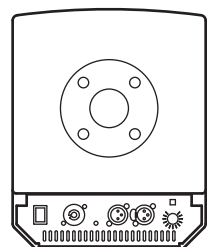

EX26 User Guide

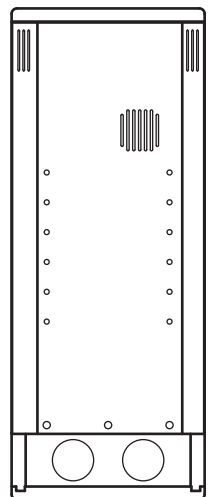
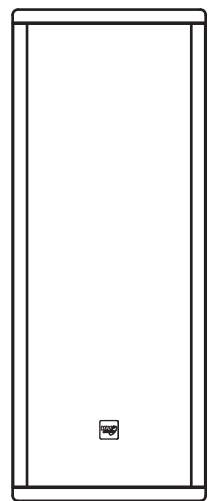
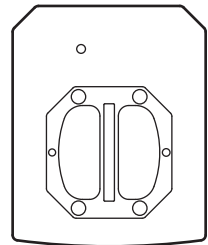
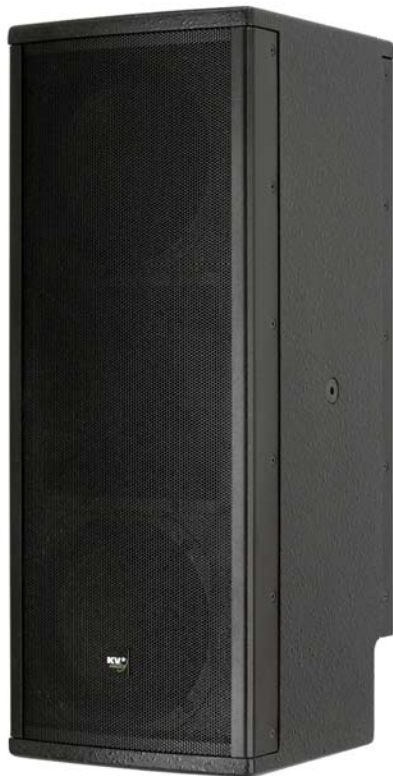

The future of sound. Made perfectly clear.

At KV2 Audio our vision is to constantly develop technologies that eliminate distortion and loss of information providing a true dynamic representation of the source.

Our aim is to create audio products that absorb you, place you within the performance and deliver a listening experience beyond expectation.

Contents

Introduction

| | |
|-------------------------------|---|
| How to use this manual | 3 |
| Icons used include | 3 |
| Important Safety Instructions | 3 |
| Introducing the EX26 | 4 |
| Electronics | 4 |
| Acoustic Components | 4 |
| Enclosure Design | 5 |

Chapter 1: AC Power Requirements

| | |
|------------------------|---|
| AC Power | 6 |
| Voltage Requirements | 6 |
| The Power Connector | 6 |
| Current Requirements | 7 |
| AC Cable Colour Coding | 7 |
| Safety Summary | 7 |

Chapter 2: Audio Signal

| | |
|------------------------|---|
| The EX26 Control Panel | 8 |
| Audio Input and Output | 8 |
| Power On / Signal LED | 9 |
| Low Cut Switch | 9 |
| Limiter | 9 |
| Thermal Protection | 9 |
| Transportation | 9 |

Chapter 3: Using Multiple Boxes

| | |
|----------------------|----|
| Using Multiple Boxes | 10 |
|----------------------|----|

| | |
|----------------------------|-----------|
| EX26 Specifications | 11 |
|----------------------------|-----------|

Warranty

Your EX26 is covered against defects in material and workmanship. Refer to your supplier for more details.

Service

In the unlikely event that your EX26 develops a problem, it must be returned to an authorised distributor, service centre or shipped directly to our factory. Because of the complexity of the design and the risk of electrical shock, all repairs must be attempted only by qualified technical personnel. If the unit needs to be shipped back to the factory, it must be sent in its original carton. If improperly packed, the unit may be damaged. To obtain service, contact your nearest KV2 Audio Service Centre, Distributor or Dealer.

How to use this manual

As you read this manual, you'll find figures and diagrams to help you understand and visualise what you're reading. You'll also find numerous icons that serve as cues to flag important information or warn you against improper or potentially harmful activities.

Icons Used Include



"NOTE" identifies an important or useful piece of information relating to the topic under discussion.



"TIP" offers a helpful tip relevant to the topic at hand.



"CAUTION" gives notice that an action can have serious consequences and could cause harm to equipment or personnel, delays, or other problems.

Important Safety Instructions

1. Read all product instructions.
2. Keep printed instructions, do not throw away.
3. Respect and review all warnings.
4. Follow all instructions.
5. Do not use this loudspeaker near water, in unprotected out door areas or in rain or wet conditions.
6. Clean only with dry cloth.
7. Do not block any ventilation openings.
8. Install in accordance with KV2 Audio recommended installation instructions.
9. Do not install near any heat sources such as heat radiators, heat registers, stoves, or other apparatus that produce heat.

10. Do not defeat the safety purpose of the grounding type plug. A grounding type plug has two blades and a third grounding connector. The third connector is provided for your safety. If the provided plug does not fit into your outlet, consult an electrician for replacement of the obsolete outlet.

11. Protect the power cord from being walked on or pinched, particularly at plugs, convenience receptacles, and the point where they exit from the loudspeaker. The AC mains plug or appliance coupler shall remain readily accessible for operation.

12. Only use accessories specified by KV2 Audio.

13. Install the product only with rigging specified by KV2 Audio, or sold with the loudspeaker.



CAUTION: Rigging should only be done by experienced professionals.

14. Unplug this loudspeaker during lightning storms or when unused for long periods of time.

15. Refer all servicing to qualified service personnel. Servicing is required when the loudspeaker has been damaged in any way, such as when the power-supply cord or plug has been damaged; liquid has been spilled or objects have fallen into the loudspeaker; rain or moisture has entered the loudspeaker; the loudspeaker has been dropped; or when for undetermined reasons the loudspeaker does not operate normally.

Introducing the EX26

The EX26 is a 2-way high output, active, compact, full-range speaker system. Design objectives for the EX26 were focused on the expansion of KV2 Audio's primary philosophy of speakers systems with increased dynamic range, very high output and a consistent sound character no matter what the output level. The EX26 sets new levels of performance for compact cabinets achieved through the integration of new amplifier, transducer and electronic control technologies that are closely tied to a passion for taking performance to the next level.

Electronics

Amplifier power, electronic crossovers, phase alignment, equalisation and speaker protection are integrated into the EX26's amplifier module.

The EX26's high frequency compression driver is powered and controlled by KV2 Audio's standard low intermodulation distortion, Class A/B, push-pull, designed to produce the lowest intermodulation distortion possible and the highest audio quality in the critical mid and high operating bands.

An improved version of KV2 Audio's current enhancing, bass driver switching amplifier has been developed for the EX26. The new configuration improves overall system efficiency and increases output allowing passive radiation of heat to take place through a unique "fin-less" heat sink that can be placed in any position or direction. Additionally, the EX26 amplifier unit contains an internally located electric fan that is operated by a temperature sensing circuit which will slowly bring the fan online as required.

Acoustic Components

The EX26's patent pending NVPD neodymium compression driver is loaded on a constant directivity horn designed for smooth, wide dispersion performance. More importantly, it has also been designed to precisely match the power response of the woofers at the crossover frequency, a crucial design objective that ensures smooth transition and minimizes anomalies.

The EX26 horn design is based on constant-directivity geometry with an emphasis on generating very low air distortion artifacts, maintaining low transducer compression ratios, high output and wide dispersion (100° x 100°).

The horn is an injected molded aluminium part that functions as a heat dissipater for the compression driver's neodymium magnetic motor structure.

Enclosure Design

The EX26 is a very compact, asymmetrical geometry enclosure design allowing it to be used in a variety of applications.

A specially moulded aluminium handle was designed and fitted to the top of the cabinet. It functions as the principle pick up handle as well as providing several fixed installation and hanging solutions. It has a centrally located M10 hang point as well as four additional M6 bracket points found underneath the KV2 logo.



EX26 HWB

The handle's M10 point is used alongside a retro fittable M10 plate on the bottom of the box (fitted in place of the existing "top-hat") when utilising an EX26 HWB (horizontal bracket). Four principal mounting bolts also provide an Omnimount™ bracket point.

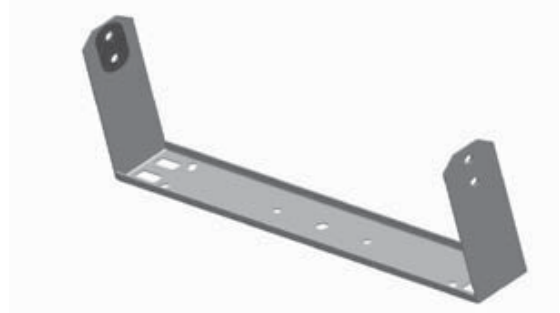

EX26 VWB

There are two side-mounted M10 hang points that can be used with the EX26 VWB (vertical bracket) or eyebolts.



Chapter 1: AC Power Requirements

The EX26 is an advanced self-powered loudspeaker with on-board amplification and control systems. Understanding power distribution, voltage and current requirements, as well as electrical safety issues, is critical to the safe operation of the EX26.

AC Power

The EX26 uses a PowerCon 3-pole AC main system with locking connectors to prevent accidental disconnection. The main AC connector (blue) serves as the power input.

The EX26 operates in either 115V or 230V modes. Although pre-configured at the factory, the unit's operating voltage mode can be changed in the field.

Voltage Requirements

The EX26 operates safely and without audio discontinuity if the AC voltage stays within the operating window of 100V-130V in 115V mode and 200V-250V when working in 230V mode, at 50 or 60Hz.



CAUTION: If the On LED does not illuminate or the system does not respond to audio input, remove AC power immediately. Verify that the voltage is within the proper range. If the problem persists, please contact KV2 Audio or an authorized service center.

If the voltage drops below the low boundary of its safe operating range, the loudspeaker will shut down if the voltage does not rise above the low boundary before storage circuits are depleted. How long the loudspeaker will continue to function during brownout depends on the amount of voltage drop and the audio source level during the drop. If the voltage increases above the upper boundary of the range, the power supply can be damaged.



NOTE: It is recommended that the voltage supply be within the rated voltage window. This ensures that AC voltage variations from the service entry - or peak voltage drops due to cable runs - do not cause the amplifier to cycle on and off or cause damage to the power supply.



NOTE: For best performance, the AC cable voltage drop should not exceed 10 volts, or 10 percent at 115 volts and 5 percent at 230 volts.

Make sure that even with the AC voltage drop, the AC voltage always stays within recommended operating ranges. The minimum electrical service amperage required by an EX26 speaker system is the sum of each loudspeaker's maximum continuous rms current. An additional 50 percent above that amperage is recommended to prevent peak voltage drops at the service entry.

The Power Connector

The EX26 requires a grounded outlet. It is very important that the loudspeaker AC supply be properly grounded in order to operate safely and properly. Use the PowerCon AC cable-wiring diagram overleaf to create international or special-purpose power connectors:

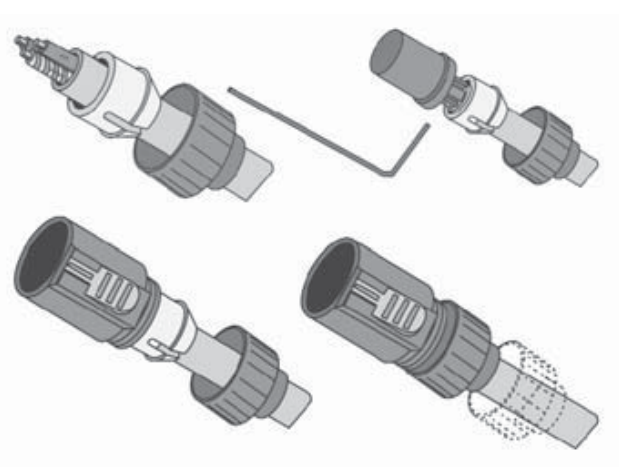

Current Requirements

Each EX26 requires approximately 4 Amps max at 115V AC for proper operation. This allows up to three EX26's to be powered from one 15 A breaker at 115V and up to seven EX26's at 230V.

The EX26 presents a dynamic load to the AC mains, which causes the amount of current to fluctuate depending on quiet or loud operating levels. Since different cables and circuit breakers heat up at varying rates, it is essential to understand the types of current ratings and how they correspond to circuit breaker and cable specifications.

The maximum long-term continuous current is the maximum rms current during a period of at least ten seconds. It is used to calculate the temperature rise in cables, in order to select a cable size and gauge that conforms to electrical code standards. It is also used to select the rating for slow-reacting thermal breakers.

The burst current is the maximum rms current during a period of approximately one second, used to select the rating of most magnetic breakers and to calculate the peak voltage drop in long AC cables according to the formula:
 $V_{pk}(\text{drop}) = I_{pk} \times R(\text{cable total})$

The ultimate short-term peak current is used to select the rating of fast reacting magnetic breakers. Use the table below as a guide when selecting cable gauge size and circuit breaker ratings for your operating voltage.

| Current Draw | 115V Mode | 230V Mode |
|--------------------------|-----------|-----------|
| Max Long Term Continuous | 4 A rms | 2 A rms |
| Burst Current | 6 A rms | 4 A rms |
| Short Term Peak | 16 A peak | 8 A peak |

AC Cable Colour Coding

If the colours referred to in the diagram don't correspond to the terminals in your plug, use the following guidelines: Connect the blue wire to the terminal marked with a N or coloured black. Connect the brown wire to the terminal marked with an L or coloured red. Connect the green and yellow wire to the terminal marked with an E or coloured green or green and yellow.

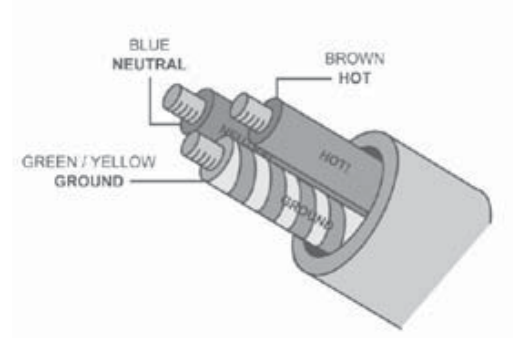

CAUTION: The EX26 requires a ground connection. Always use a grounded outlet and plug.

Safety Summary

To reduce the risk of electric shock, disconnect the loudspeaker from the AC mains before installing audio cable. Reconnect the power cord only after making all signal connections. Connect the loudspeaker to a two pole, three-wire grounding mains receptacle.

The receptacle must be connected to a fuse or circuit breaker. Connection to any other type of receptacle poses a shock hazard and may violate local electrical codes. Do not allow water or any foreign object to get inside the loudspeaker. Do not put objects containing liquid on or near the unit. To reduce the risk of overheating the loudspeaker, avoid exposing it to direct sunlight. Do not install the unit near heat-emitting appliances, such as a room heater or stove. This loudspeaker contains potentially hazardous voltages. Do not attempt to disassemble the unit. The unit contains no user serviceable parts, repairs should be performed only by factory trained service personnel.

Chapter 2: Audio Signal

The EX26 Control Panel

The EX26 features an easy to use control panel featuring AC power in, audio input and through output, level control, LED status light and a High Pass filter.

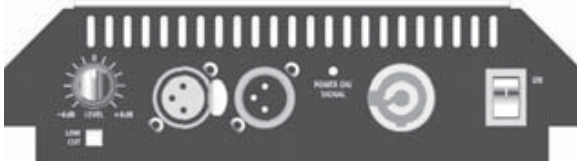

Audio Input and Output

The EX26 uses a balanced, female XLR connector for the audio input connector, and a male XLR connector to provide through output signal. The through output connector, wired in parallel to the audio input, will continue to provide the input signal if the EX26 is turned off. The audio input circuit presents a 20 k Ω balanced input impedance to a three-pin XLR connector with the following connections:

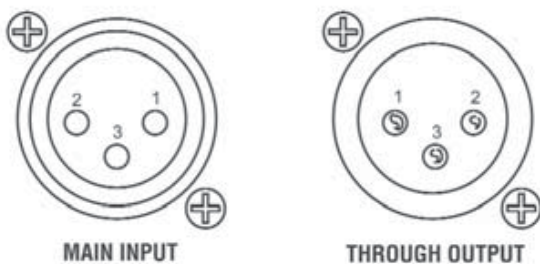

Pin1 -1 k Ω to chassis and earth ground

Pin 2 -Signal (+)

Pin 3 -Signal (-)

Case -Earth (AC) ground and chassis

Audio signal can be daisy-chained using the through output connector on the input panel. A single source can drive multiple EX26 speakers with a paralleled input loop. If you are driving multiple EX26's make certain that the source device can drive the total load impedance presented by the paralleled input circuits.

The audio source must be capable of producing a minimum of 1.0V volts rms to produce the maximum peak SPL over the operating bandwidth of the loudspeaker.

To avoid distortion from the source, make sure the source equipment provides an adequate drive circuit design for the total paralleled load impedance presented by the speakers. The input impedance for a single loudspeaker is 20 k Ω . If "n" represents the number of EX26 loudspeakers in a system, paralleling the inputs of n loudspeakers will produce a balanced input load of 20 k Ω divided by "n".



TIP: If the loudspeaker produces noises such as hiss and popping, disconnect the audio cable from the loudspeaker, if the noise stops, then most likely the problem is not with the loudspeaker. Check the audio cable, source, and AC power for the source of the problem.



NOTE: Ensure that all cabling carrying signal to multiple amplifiers and active speaker systems is wired correctly. Make sure that the polarity has not been reversed. Reversed polarity can cause severe degradation in frequency response and can also impact the dispersion characteristics of the speaker.

Power On / Signal LED

This LED turns green when the speaker is turned ON. The light will turn yellow when signal is present.

Low Cut Switch

The EX26 features a 90Hz High Pass Filter. Pressing the button engages this filter allowing the speaker to reproduce frequencies only above 90Hz

Limiter

The EX26 employs a protection system based on rms limiting of the amplifiers. This type of protection strategy allows the speaker to operate safely under overload conditions. When the rms "limiter" engages, the output level of both amplifiers is reduced to a safe operating level. This type of protection allows the frequency response of the system to remain unchanged as the level is lowered. By not compressing or limiting peak signal, dynamics also remain unchanged. The control objective is to regulate the operating temperature of the transducers magnetic circuits long term. This ensures no impact on performance due to power compression and allows the components to retain their ability to reproduce high dynamics. When overdriven the rms limiter will disengage only if the input level is turned down.

Thermal Protection

In the unlikely event of over heating the speaker system will shut down. You can expect for the system to be down for at least 2-3 minutes depending on the ambient temperature and whether the system is being exposed to direct sun light.



NOTE: The EX26 features a finless heatsink that allows it to operate in any position. There is also an internal fan located inside the amplifier module. The fan speed is dependent on two factors; the temperature of the heat sink and the output level of the speaker. As temperature increases, so does fan speed. As audio level increases, fan speed also increases as a preventative measure designed to keep the heat sink temperature low. Under normal operating conditions, the fan noise remains inaudible. Please contact KV2 Audio or a local service representative should the system enter a thermal condition under normal operating conditions.

Transportation

To keep your EX26 speakers in optimum condition we recommend transportation in an optional KV2 Audio EX26 padded nylon cover (EX26CVR) or a professional road case.

Chapter 3 Using Multiple Boxes

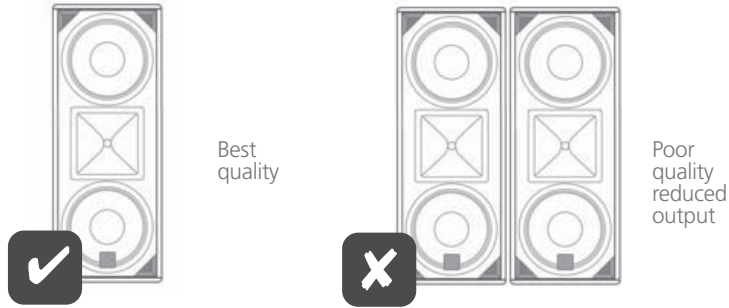

Fig. A



Fig. C

KV2 speakers are far more accurate, defined and phase coherent than virtually any other loudspeaker on the market. This very defined phase accuracy comes into play when trying to stack the speakers.

It is very important not to use KV2 Audio Mid-High boxes directly side by side. (Fig. A) This will produce a poor quality sound cancelling out perfectly, which reduces overall output. Defined by the way our ears work, their position on our heads and the brain's understanding of the signals they produce, each ear will hear two sources in the horizontal plane very close together, but very slightly misaligned in arrival time.

With our ears positioned on each side of our head, rather than on the top and bottom, they are very good at pinpointing precisely a sound in the Horizontal plane (i.e. it's exact position left to right in the sound field). Vertically (trying to pin point sound up and down) they are far less accurate and have a greater tolerance for error. Receiving multiple signals so phase

Fig. B

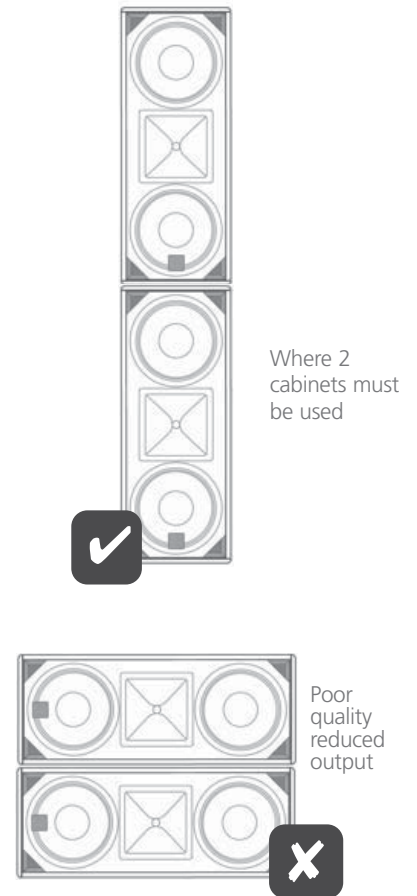

coherent, but misaligned horizontally, leads the brain to get confused, which in turn leads it to interpret a confused poor quality, low intelligibility sound.

KV2 exploits the additional vertical tolerance that the brain has by only stacking multiple cabinets vertically, as do modern Line arrays, but KV2 still keeps as close as possible to the theory of point source by using a maximum of two cabinets together, keeping the horns as far apart as possible. (Fig. B) This reduces the cancellations that most line arrays suffer from particularly in the high frequencies.

The only exception to this maximum of two cabinets would be in a down fill / side fill application where an additional cabinet can be deployed but must be separated from the main forward firing system by an amount of degrees equivalent to the vertical or horizontal dispersion of that speaker. (Fig. C)

Combining boxes and building systems in this way will give the maximum overall output, best audio quality and consistent, even coverage.

EX26 Specifications

| | |
|--|---|
| System Acoustic Performance | |
| -3dB Response | 87Hz – 20kHz |
| -10dB Response | 68Hz – 28kHz |
| Max SPL Long-term | 124dB |
| Max SPL Peak | 127dB |
| Crossover Point | 2.5kHz |
| High Frequency Section | |
| Throat Exit Diameter / Diaphragm Size | 1" / 1.75" |
| Diaphragm Material | Nitride Titanium |
| Magnet Type | Neodymium |
| Horn with Constant Directivity | |
| Coverage Horizontal / Vertical | 100° x 100° |
| High Frequency Amplifier Specification | |
| Type | Class AB |
| Rated Continuous Power | 20 W |
| Distortion | <0.05% |
| Operating Bandwidth | 2.5kHz – 28kHz |
| Low Frequency Section | |
| Acoustic Design | |
| Woofer Size / Voice Coil Diameter / Design | Front Loaded, Bass Reflex 2 x 6" / 1.75" |
| Diaphragm Material | Epoxy Reinforced Cellulose |
| Magnet Type | Neodymium |
| Bass Amplifier Specification | |
| Type | High Efficiency Switching |
| Rated Continuous Power | 350W |
| Distortion | <0.05% |
| Operating Bandwidth | 87Hz – 2.5kHz |
| Signal Input | |
| Input Impedance | 20 kΩ |
| Input Sensitivity | 1.0 V rms |
| Physical Dimensions | |
| Height | 570mm (22.44") |
| Width | 220mm (8.66") |
| Depth | 270mm (10.63") |
| Weight | 16kg (35.2lbs) |
| Power Connector | |
| | Neutrik PowerCon® |
| Operating Voltage | |
| | 100-120V @ 60Hz 230-250V @ 50Hz |
| Recommended Amperage | |
| | 4A 115V 2A 230V |

The future of sound. Made perfectly clear.

At KV2 Audio our vision is to constantly develop technologies that eliminate distortion and loss of information providing a true dynamic representation of the source.

Our aim is to create audio products that absorb you, place you within the performance and deliver a listening experience beyond expectation.



KV2 Audio, Nádražní 936, 399 01 Milevsko, Czech Republic
Tel. +44(0)1423 816868
www.kv2audio.com