

6ND410

Very High Output Midrange Neo Transducer

Key Features

- 102 dB SPL 1W / 1m average sensitivity
- 45 mm (1,77 in) edgewound aluminum voice coil
- 180 W AES power handling
- Neodymium motor assembly
- Extremely high sound quality
- Very shallow profile, 58 mm (2,3 in)
- Suitable for horn and direct radiation midrange applications



General Description

The 6ND410 is a very high output, state-of-the-art midrange product for high quality professional use. The high level of sound quality has been achieved thanks to extensive research by Eighteen Sound engineers which focused on implementing mid frequencies intelligibility.

The 6ND410 can be used as a midrange in both horn and direct radiation, closed or reflex enclosures, as small as 2 liters. The extremely powerful external neodymium magnet assembly assures high flux concentration, low power compression and excellent heat exchange. Consequently, the levels of force factor and power handling are at a top professional level with an optimum power to weight ratio. A consistent heat transfer is guaranteed by the encapsulation of the magnetic structure in the interior of the basket, offering a large contact space between the back plate and the dissipating structure. The curvilinear cone-surround, has been created using computer aided vibrational modelling software to move all undesired bell modes out of the usable frequency range.

The 45 mm edge-wound voice coil assembly and terminals have been designed to minimise the moving mass while reinforcing force transmission.

The 3 threaded back plate holes give the final user the opportunity to insert an external customised heat sink, if further heat dissipation is required.

A proprietary humidity-block cone treatment makes the transducer suitable for outdoor use in adverse weather conditions. In addition, a special coating applied to both the top and back plates makes the 6ND410 far more resistant to the corrosive effects of salts and oxidization.

022068N510 8 Ohm
022066N510 16 Ohm

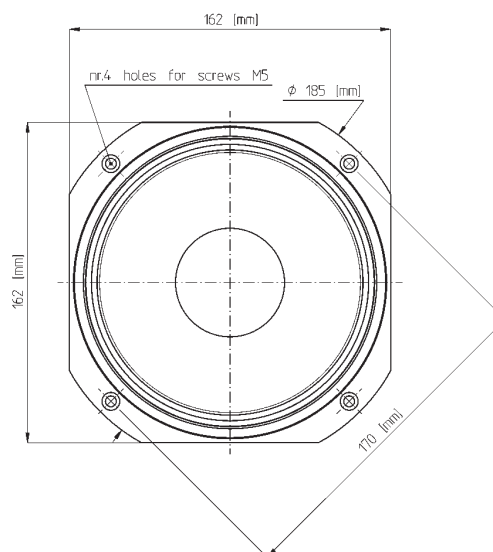
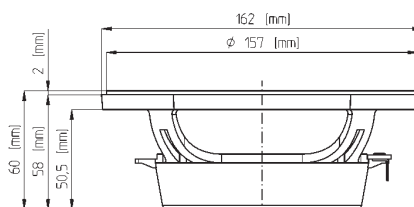

NEODYMIUM LF-MB-MF TRANSDUCERS

6ND410

Very High Output Midrange Neo Transducer

GENERAL SPECIFICATIONS

NOMINAL DIAMETER	152mm (6 in)
RATED IMPEDANCE	8 Ohm
AES POWER (1)	180 W
PROGRAM POWER (2)	240 W
PEAK POWER (3)	480 W
SENSITIVITY (4)	102 dB
FREQUENCY RANGE (5)	200 ÷ 8000 Hz
POWER COMPRESSION @-10DB (6)	0,7 dB
POWER COMPRESSION @-3DB	1,2 dB
POWER COMPRESSION @FULL POWER	1,6 dB
MAX RECOMM. FREQUENCY	5000 Hz
RECOMM. ENCLOSURE VOLUME	1 ÷ 5 lt. (0,04 ÷ 0,18 cuft)
MINIMUM IMPEDANCE	8,2 Ohm at 25°C
MAX PEAK TO PEAK EXCURSION	8 mm (0,31 in)
VOICE COIL DIAMETER	44 mm (1,75 in)
VOICE COIL WINDING MATERIAL	aluminum
SUSPENSION	Progressive double roll, Polycotton
CONE	Curvilinear, Paper

THIELE SMALL PARAMETERS (7)

Fs	120 Hz
Re	5,9 Ohm
Sd	0,0143 sq.mt. (20,6 sq.in.)
Qms	2,2
Qes	0,27
Qts	0,24
Vas	6,2 lt. (0,22 cuft)
Mms	8,2 gr. (0,02 lb)
BL	11,6 Tm
Linear Mathematical Xmax (8)	± 2 mm (±0,08 in)
Le (1kHz)	0,67 mH
Ref. Efficiency 1W@1m (half space)	97,9 dB

MOUNTING INFORMATION

Overall diameter	162 mm (6,38 in)
N. of mounting holes	4
Mounting holes diameter	5,5 mm (0,22 in)
Bolt circle diameter	170 mm (6,69 in)
Front mount baffle cutout ø	148 mm (5,83 in)
Rear mount baffle cutout ø	148 mm (5,83 in)
Total depth	60 mm (2,3 in)
Flange and gasket thickness	9,5 mm (0,37 in)
Net weight	1,25 kg (2,76 lb)
Shipping weight	1,8 kg (3,97 lb)
CardBoard Packaging dimensions	170 x 170 x 80 mm (6,69 x 6,69 x 3,15 in)

FREQUENCY RESPONSE CURVE OF 6ND410 MADE ON 2 LIT. CLOSED ENCLOSURE IN FREE FIELD (4PI) ENVIRONMENT. ENCLOSURE CLOSES THE REAR OF THE DRIVER. THE THIN LINE REPRESENTS 45 DEG. OFF AXIS FREQUENCY RESPONSE

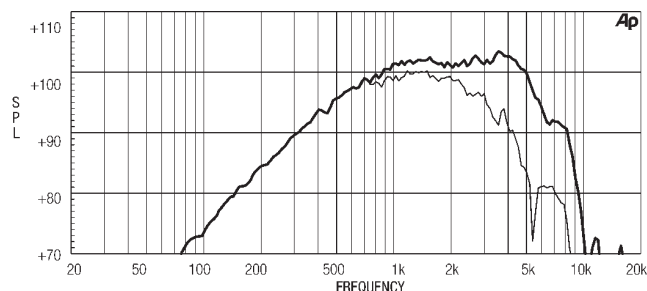

FREE AIR IMPEDANCE MAGNITUDE CURVE

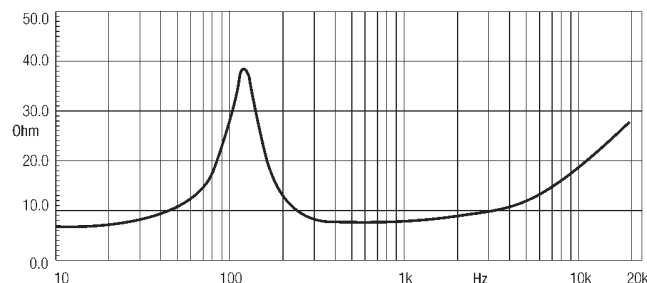

NOTES

- (1) AES power is determined according to AES2-1984 (r2003) standard
- (2) Program power rating is measured in 2 lit closed enclosure using a 300 -3000Hz band limited pink noise test signal with 50% duty cycle, applied for 2 hours.
- (3) The peak power rating represents the maximum permitted instantaneous peak power level over a maximum period of 10ms which will be withstood by the loudspeaker without damage.
- (4) Sensitivity represents the averaged value of acoustic output as measured on the forward central axis of cone, at distance 1m from the baffle panel, when connected to 2,83V sine wave test signal swept between 500Hz and 2500Hz with the test specimen mounted in the same enclosure as given for (1) above.
- (5) Frequency range is given as the band of frequencies delineated by the lower and upper limits where the output level drops by 10 dB below the rated sensitivity in half space environment.
- (6) Power compression represents the loss of sensitivity for the specified power, measured from 100-1000 Hz, after a 5 min pink noise preconditioning test at the specified power.
- (7) Thiele - Small parameters are measured after the test specimen has been conditioned by 180 W AES power and represent the expected long term parameters after a short period of use.
- (8) Linear Math. Xmax is calculated as $(Hvc-Hg)/2 + Hg/4$ where Hvc is the coil depth and Hg is the gap depth.

Eighteen Sound engages in research and product improvement. New materials and design refinements can be introduced into existing products without notice.

